



Boarding and Deck Equipment
SAILING YACHTS

Embark on a journey to enjoy and elevate your sailing experience with Båtsystem's high-quality solutions, developed and refined over decades

Your safety and convenience are our top priorities. Whether you're stepping aboard from a dock, a dinghy, or the water itself, our innovative solutions make every boarding experience safe and effortless.

Designed with focus on functionality and quality, offering a wide range of items. These include sturdy ladders, lifting devices, anchor holders, stern and bow platforms and other deck equipment that suits various types of sailing boats.

Experience the peace of mind of knowing that you and your loved ones are safe and sound on the water.

Båtsystem | A better boating experience





CONTENT

Introduction	4-5
Ladders	6-15
Bow platforms	16-34
Stanchions and anchor holders	35-36
Stern platforms	38-41
Davits and cranes	42-47
Anchoring	48-49
Deck equipment	50-51
Spare parts	52

Disclaimer:

Products shown in this catalogue are designed to be used as accessories for sailboats in the water and are not intended for any other purpose. The user assumes all risks associated with the use of the product, including but not limited to personal injury, property damage, and loss of life. The manufacturer and seller are not responsible for any accidents, injuries, or damages caused by the improper installation, use, or maintenance of the product. The user is responsible for ensuring that the product is installed and used in accordance with all applicable laws and regulations. This product may not be compatible with all sailboats. Please consult the product manual for specific compatibility information. The manufacturer and seller reserve the right to change or discontinue the product at any time without notice.

We have always strived to make the life we love easier

Whether you're planning a short day trip, a coastal holiday sail, an ocean crossing, or a voyage around the world, Båtsystem has the products you need to get you, your family and your gear safely on and off the boat. We offer equipment for every situation, for all ages - young and old - and even for your pet, dinghy, and outboard engine. Since the late 1980s, our passion has been making boarding easier with ladders, bow and stern platforms, davits, cranes, and other deck equipment. In this catalogue, you'll find helpful guidance and products to enhance your sailing experience.



Båtsystem was founded in the late 1980's

Båtsystem was founded in the late 1980s and has grown from a small company into a well-known brand, recognized for its reliable, high-quality products. Today, we export far beyond Scandinavia, reaching Europe and markets worldwide. While much has changed since our early days, our core values remain the same: customer-driven product development and exceptional customer service.



LADDERS

A ladder will get you there

A ladder mounted to your boat is a must, whether you prefer it at the transom, onto a bathing platform or on the side of the boat where the impact of waves is minimal. A ladder on a bowsprit can also come in handy to reach the dock or land from the bow.

Most important is that there is a rescue ladder easily accessible from the water, in case of an unintentional plunge (MOB). But ladders is not only a matter of safety, it's also about convenience, accessibility and the freedom to get on land wherever you like.



GUIDE | STEP-BY-STEP

- 1 Make sure it is long enough**
For maximum safety, have a ladder that reaches minimum 55 cm under the waterline. And for that extra comfort add one more step giving you at least 3 steps under water.
- 2 Comfortable steps**
Both small and large feet can slip when they are wet. Make sure the ladder has footsteps that are comfortable to climb on and provide a safe grip. All of Båtsystem ladders have flat, comfy steps with rifled surface, most of them wide enough to place two feet side by side - safe and comfortable.
- 3 Something to hold on to**
Make sure that the ladder takes you all the way up into the boat. Several of our ladder models have built-in handles that make it easier to board and disembark. The models which do not have it, such as the smooth ladders in casing, can be complemented with removable handles attached to the bowsprit or the platform.



RIB

Ladders specifically designed for RIB boats.



SIDE

When boarding from the side with a RIB as well as from the bridge.



IN CASING

To minimize stowing space.



HOOK

For the bow and the bowsprit.
Easy to hook on and off.



BOW

For quick and easy mounting on bow or pulpit.



SAFETY AND BATHING (MOB)

Accessible all the way from water to deck.

RIB LADDERS



Ladders for RIB that takes you all the way up.

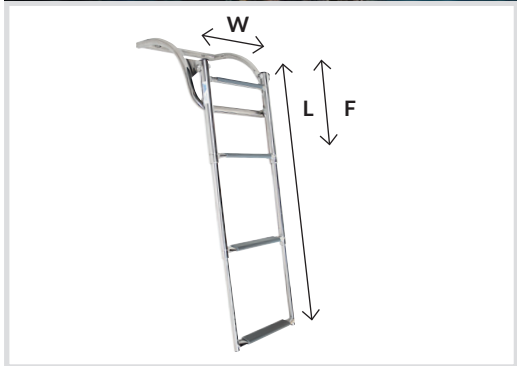

RIB400

RIB500



Art	L (mm)	F (mm)	W (mm)	Tube diameter, boat (mm)	Folding
RIB400	868	375	340	400	Telescopic
RIB500	1160	410	350	500	Telescopic



Hang mounting
Hung on the tube and tightened with safety bands.



Comfortable steps



Hook fittings
The ladder is attached to the hull with hook fitting.



The RIB ladder is resting on the boat's tube and is secured with two straps.



SIDE LADDERS



A sturdy, well-built ladder makes boarding or disembarking from your boat a safe and easy task.



Sturdy handles
For extra good grip.



Foldable
the last step on SL95R and the three last steps on SL150R are foldable.



Hook fittings
Easy to attach and detach.



Padded hullsupport
Foldable.



Pivoting handles
For better stowing.



Teak steps
Optional



Bag
Optional



SL65R

SL95R

SL150R



Art	L (mm)	W (mm)	D (mm)	c/c mm	Steps
SL65R	630	268	189	265	2
SL95R	950	268	189	265	3
SL150R	1520	280	245	265	6

LADDERS IN CASING - STANDARD



Ladders in casing, for bowsprit or bathing platform. The ladder expands in two, three or four steps and is easily locked.



Locking
Smart locking mechanism.



Comfortable steps



Foldable
Folds down under platform or bowsprit.



High handles
Folds with ladder. BKTH-ladders.

Art	L (mm)	W (mm)	D (mm)	H (mm)	Step	Folding
BKT72-250	600	250	300	65	2 Plastic	Casing/telescope
BKT73-250	880	250	300	65	3 Plastic	Casing/telescope
BKT72	600	285	300	65	2 Plastic	Casing/telescope
BKT73	880	290	300	65	3 Plastic	Casing/telescope
BKT73T	880	290	300	65	3 Teak	Casing/telescope
BKT74	1160	310	320	80	4 Plastic	Casing/telescope
BKT74T	1160	310	320	80	4 Teak	Casing/telescope
BKTH73	880	411	385	75	3 Plastic	Casing/telescope
BKTH74	1200	415	420	75	4 Plastic	Casing/telescope
BKB73	880	340 (box)	490 (box)	50 (box)	3 Plastic	Telescopic in box
BKB74	1160	340 (box)	490 (box)	50 (box)	4 Plastic	Telescopic in box

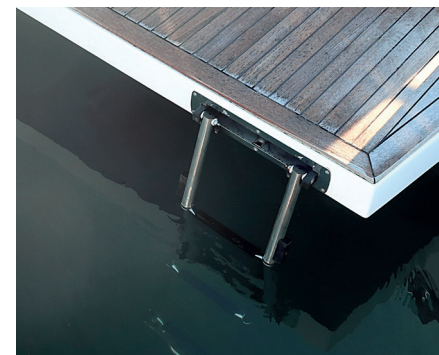

LADDERS IN CASING - LARGE ANCHOR



Ladder in casing for the Performance and Ultimate bowsprit (PB1200 / PB1400 / ULT1200 / ULT1400) with larger anchors.



Locking
Smart locking mechanism.



Comfortable steps



Foldable
Folds down under bowsprit.



No strut
More space for larger anchor.



LADDERS IN CASING - ROPE CONTROL

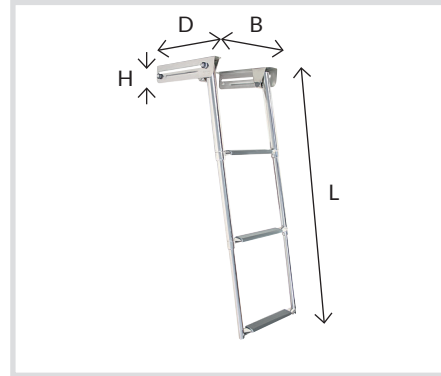

Ladder in casing for bowsprit and bathing platform. Ropes for pulling up and lowering down.

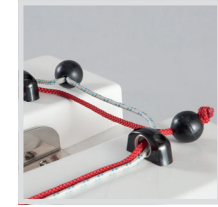

Rope control
Ropes for raising and folding.



Comfortable steps



Foldable
Folds down under platform or bowsprit. Rounded design to match the bowsprit.



Art	L (mm)	B (mm)	D (mm)	H (mm)	Steps	Folding
BKT73A	880	295	300	65	3	Casing/telescope

Art	L (mm)	B (mm)	D (mm)	H (mm)	Steps	Folding
BKR93	880	300	360	65	3	Casing/telescope - rope controlled

HOOK LADDERS

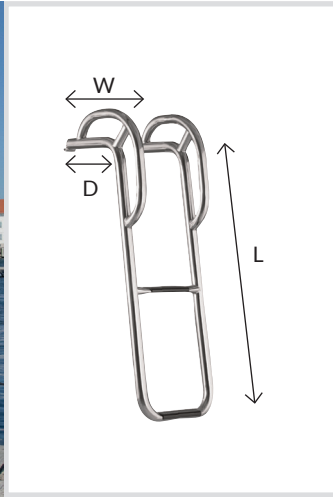

Ladders for bowsprits, with sturdy handles. Hook onto the bowsprit or on deck.



BU60P BU75P BU75P-4 BU76P-12 BU80P BU80F BU80P-4

Art	L (mm)	W (mm)	D (mm)	c/c mm	Steps	
BU60P	615	180	130	175	2	Aluminium
BU75P	900	220	130	200	3	
BU75P-4	1200	220	130	200	4	Last step telescopic
BU76P-12	1200	230	220	230	4	Last step telescopic
BU80P	900	290	222	265	3	
BU80P-4	1200	290	222	265	4	Last step telescopic
BU80F	900	290	222	140	3	

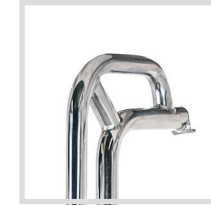

Sturdy handles
For extra good grip.



Foldable
Last step is telescopic on 4 step ladders.



Hook fittings
Easy to attach and detach.



Safety band
Secures the ladder from falling into the water.



Support
BU80F has support for extra narrow bows.



BOW LADDERS

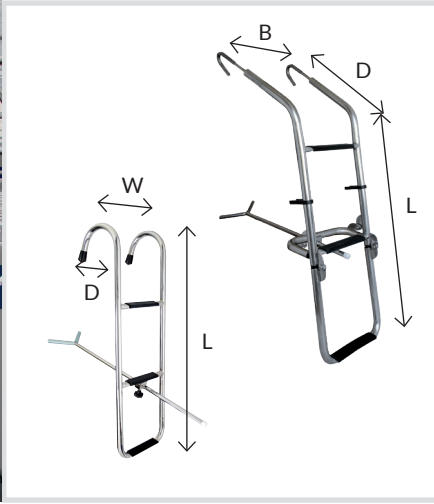

The ladder can be mounted onto pulpit or deck fitting.



Quick brackets
Easy to attach and detach.



Foldable
Easy to stow.

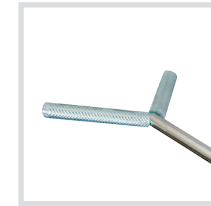

Stem strut
Adjustable.



Aluminium
Two ladders in lightweight aluminium.



Fitting P1066 for optional mounting.



Keyhole fittings for ST110SN and ST110SNR



Bag
Convenient storing.



Safety band
Secures the ladder from falling into the water.

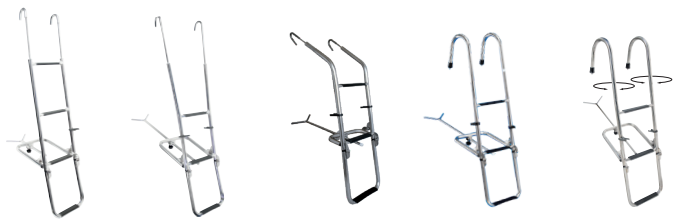

ST125AL ST130AL ST135 ST110SN ST110SNR

Art	L (mm)	W (mm)	D (mm)	Length folded	Strut (mm)	Steps	Material	Fitting
ST125AL	1240	250-300	-	740	350-1000	4	Aluminium	Hook
ST130AL	1240	350-450	-	740	350-1000	3	Aluminium	Hook
ST135	740	320-450	550	440	100-350	3	AiSi316 steel	Hook
ST110SN	1060	290	210	750	350-1000	3	AiSi316 steel	Keyhole fitting
ST110SNR	1060	290	210	750	350-1000	3	AiSi316 steel	Keyhole fitting



ST130AL is designed to fit a blunt stem, or a boat with stem anchor. The topmost step has been removed, and the upper edge is broadened, to make room for the anchor. The last step is foldable.



Keyhole fitting
Easy to attach and detach.
SN- and SNR-ladders



Pivoting handles
For better stowing.
SNR-ladder

SAFETY AND BATHING (MOB) - TRANSOM MOUNTED

BT72-180, BT72-4



BUT55, BUT55F

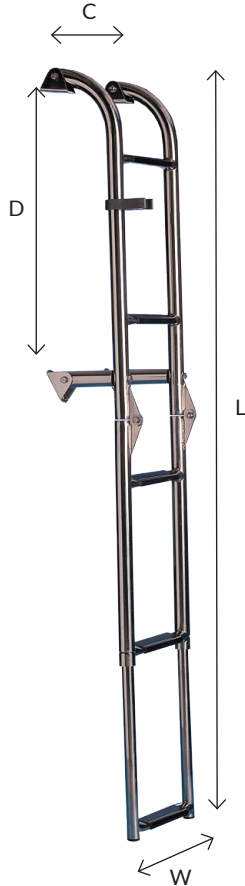

BUT40, BUT40R, BUT41, BUT41F

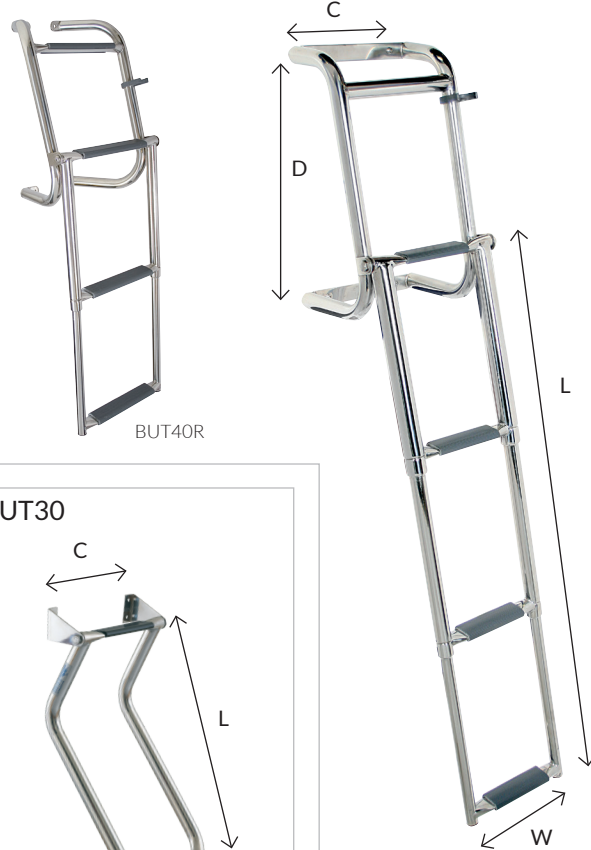

BUT30



Art	L (mm)	W (mm)	C c/c (mm)	D c/c (mm)	Length folded (mm)	Strut (mm)	Steps	Folding
BT72-180	1115	210	90	200	402	70	4	Telescope
BT72-4	1160	300	150	175	370	70	4	Telescope
BUT30	400	225	200	-	400	-	2	Folding
BUT40	590	230	125	360	360	-	4	Telescope/Folding
BUT40R	880	255	90	385	385	-	4	Telescope/Folding
BUT41	875	230	125	360	360	-	5	Telescope/Folding
BUT41F	850	230	125	360	360	-	5	Telescope/Folding
BUT55	1185	210	200	470	550	110	5	Telescope/Folding
BUT55F	1185	210	200	470	550	580	5	Telescope/Folding

SAFETY AND BATHING (MOB) - PLATFORM MOUNTED

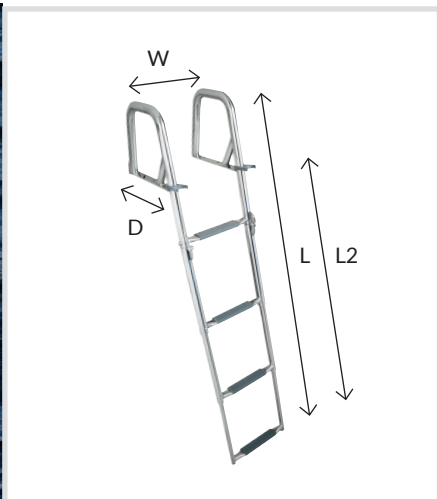

Bathing ladder with sturdy grips and universal fittings. Foot friendly steps.

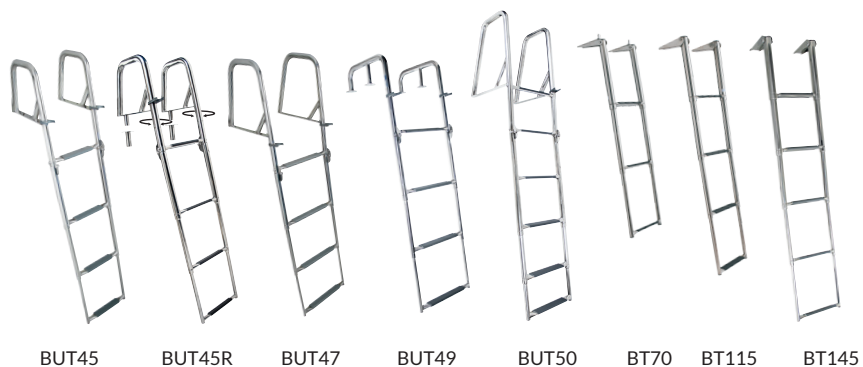

Art	L (mm)	W (mm)	D (mm)	Length folded	Steps	Handle height (mm)	c/c mm	Strut (mm)
BUT45	1300	290	260	453	4	250	255	-
BUT45R	1300	287	238	453	4	250	255	80
BUT47	1420	382	343	554	4	370	350	-
BUT49	1300	382	350	423	4	130	350	-
BT70	880	300	110	-	3	-	-	-
BT115	1160	300	110	-	4	-	-	-
BT145	1450	310	140	-	5	-	-	-

Art	L (mm)	B (mm)	D (mm)	L2(mm)	Steps	Handle height (mm)	c/c mm
BUT50	1955	400	361	1455	6	500	362
BUT60	2523	400	361	2023	8	500	362



Sturdy handles
For extra good grip.



Foldable
Telescopic.



Hole fittings
For easy and quick removal (BUT45R).

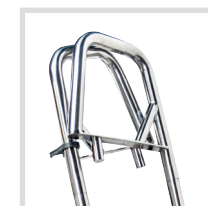

Pivoting handles
For better stowing.
(BUT45R)



Fitting
Smooth fittings for
BT-ladders.

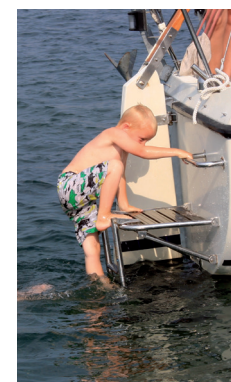

BOW PLATFORM

Extend your boating experience

A bowsprit not only enhances the look and quality of your boat. It also helps you achieve a better boating experience. Use the wind's full potential with a gennaker or Code-0 sail, get ashore on every possible and impossible place, and get easily onboard – even when your legs are too short, or too tired.

Stow your anchor forward and free up your fore deck. Avoid scratches and marks on your GRP when retrieving your dangling anchor above the waterline.



GUIDE | STEP-BY-STEP

- 1 Think longterm**
A bow platform is an investment that increases functionality as well as value of your boat. As it is necessary to make an installation with holes in the hull of your beloved sailing boat, make sure the type you choose covers both present and future needs. The bow platform will be a part of your boat for a long time ahead. And after you, someone else will take over your boat.
- 2 Make sure the bowsprit is strong enough**
Båtsystem bowsprits range from more basic needs up to more powerful sailing, anchoring and sea conditions. Don't limit present or future needs.
- 3 Match it with the hull lines**
A not so good installed bow platform drags down the overall impression of your boat. Find the lines and align the bow platform to make sure it will look like an integrated and extended part of your boat.

MODEL	KEY FEATURES	18-26"	26-33"	32-39"	39-47"
ULTIMATE	<ul style="list-style-type: none"> • Boarding • Code-0 sailing • Anchor stow • Extra strong waterstay 			ULT1200	ULT1400 ULT1500
PERFORMANCE	<ul style="list-style-type: none"> • Boarding • Code-0 sailing • Anchor stow 		PB1050	PB1200	PB1400
EDGE	<ul style="list-style-type: none"> • Boarding • Code-0 sailing • Anchor stow • Designed for vertical bow 			ED1200	
RACE	<ul style="list-style-type: none"> • Boarding • Code-0 sailing 		RACE80	RACE100	
CLASSIC	<ul style="list-style-type: none"> • Boarding • Downwind sailing 	HP65	GPT100 GPAT100		

CHOOSING BOWSPRIT FOR CODE-0



A furler and a Code 0-sail are not enough for a complete Code solution. A sturdy attachment for the furler to the boat is also needed. The idea behind Båtsystem's solution is a bowsprit designed to take care of the strong forces that occur when sailing with Code 0 - not only vertically but especially the huge sideways forces..

Which bowsprit to choose depends on the load of the code-0 and the weight of the bow anchor, if you have one. We have combined a table to make it easier to choose between our models.

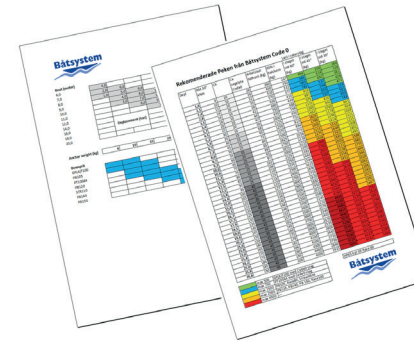

For more guides on how to choose the right equipment, visit our website www.boatsystemgroup.com

	PB1050	PB1200 ULT1200	BUT48PB	PB1400 ULT1400	ULT1500	Race80	Race100	ED1200
Gennaker 	Max 80m ²	Max 115m ²	Max 115m ²	Max 130m ²	Max 150m ²	Max 80m ²	Max 130m ²	Max 115m ²
Code-0 Working load 	1500 kg	2500 kg	2500 kg	2500 kg	2500 kg	1500 kg	2500 kg	2500 kg
Removable ladder 	✓	✓	Fixed ladder	✓	✓	✓	✓	✓
Ladder in casing 	✓	✓	✗	✓	✗	✗	✗	✓
Pulpit 	PPK600	PPK600 PPK900	-	PPK800 PPK900	PPK800 PPK900	-	-	-
Accessories	H250 P1086	H300 P1087	P1087	H300 P1087		-	-	-





ANCHOR IN BOW PLATFORM

Anchors aweigh!

Anchoring is almost like a religion and what you choose is mostly driven by the forces affecting the boat and what grip you can achieve in the seabed where you plan or need to anchor. Wind, waves, current, tide, seabed, boat type and size are some of the key variables.

We will not decide what anchor you should have even though we know a bit about it, but we know a lot of how to carry anchors in a bow platform and will hopefully guide you to the best solution for you and your boat.



GUIDE | STEP-BY-STEP

- 1 Understand your anchor type**

Anchors with a straight and heavy shank close to a 90 degree neck angle, typically BRUCE and CQR-anchors and its derivatives, are normally not self-launching and are therefore best off with a pivoting anchor roller for an easier launch and retrieval.

Anchor types with an angled or rounded profiled shank like DELTA, VULCAN, SPADE, EPSILON, ULTRA-MARINE, ROCNA, MANTUS etc. to mention a few are made to set quickly and therefore self-launching.

Anchors with roll bars (like ROCNA, MANTUS and BÜGEL) fits well if positioned far forward in our PERFORMANCE and ULTIMATE models where the roll bar lands ahead of the bowsprit. These modern anchors are also self-launching and in no need of a pivoting anchor roller.
- 2 Understand the relation between the bow and the bow platform**

Normally, a standard bow roller is integrated in the hull and not easy to remove. It makes therefore sense to keep it in combination with the new bowsprit. Due to the high number of bow designs, anchors and sizes, Båtsystem has a smart solution for most combinations (see illustrations on the next page)
- 3 With or without a ladder in the bow**

When mooring bow-to, a fixed bow ladder facilitates boarding from the bow, as typically seen in Scandinavia. This ladder must not get in conflict with your anchor and needs to be considered. Ask Båtsystem for a solution!



DELTA type anchor in sailing position

It is important to find a good stowage position for the anchor in the bowsprit where it can be fixed and remain stable during sailing. Maybe your boat already has an existing fixed bow roller in the front? In that case you may keep it using it together with the roller on the bowsprit to jointly support your anchor. As seen, the anchor is then stored with a slightly larger release angle.

Example of a plough anchor type, normally not that sensitive to different bowsprit installations.

Guide - use bow roller PB11.
Works well in most cases.



GUIDE

Without fixed bow roller

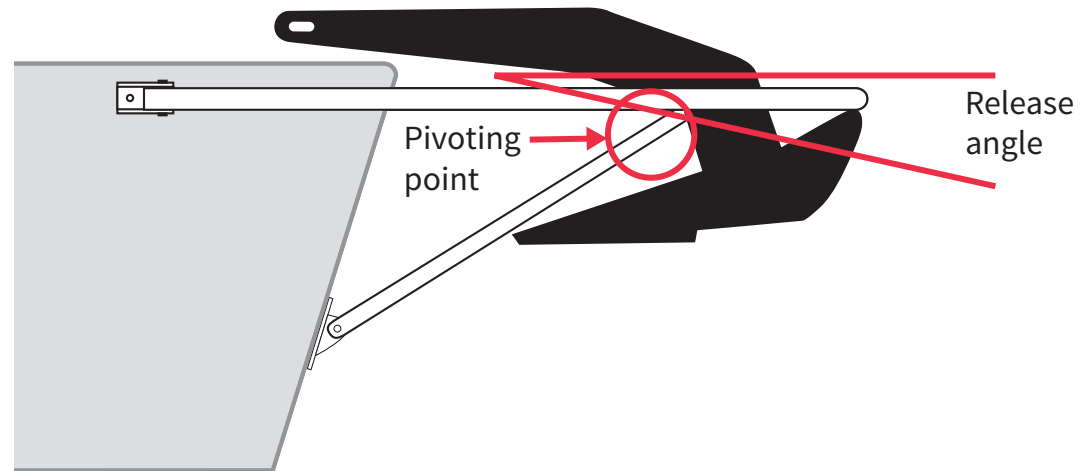

With fixed bow roller

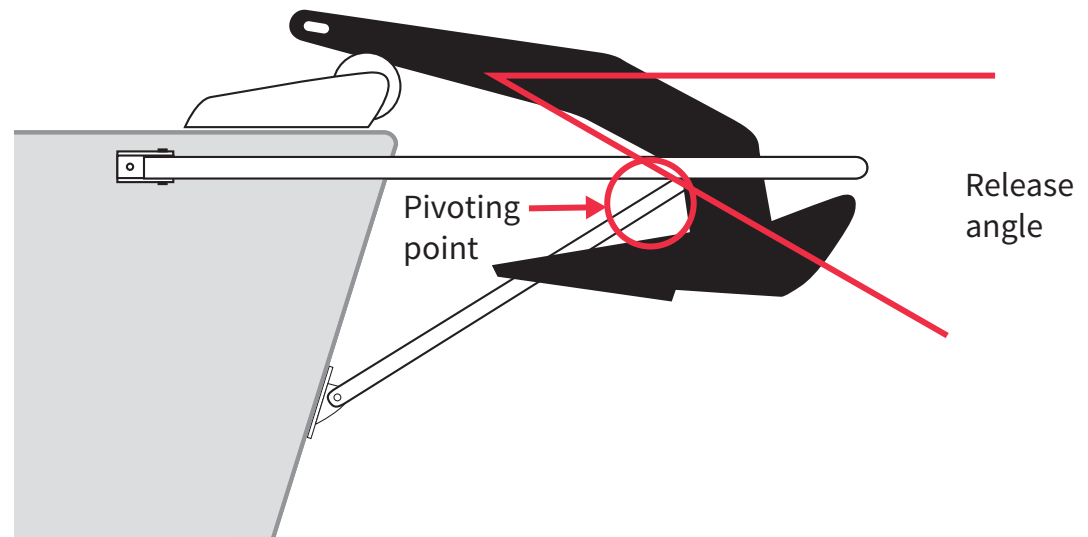

ROCNA type anchor in sailing position

It is important to find a good stowage position for the anchor in the bowsprit where it can be fixed and remain stable during sailing. Maybe your boat already has an existing fixed bow roller in the front? In that case you may keep it using it together with the roller on the bowsprit to jointly support your anchor. As seen, the anchor is then stored with a slightly larger release angle.

Example of a ROCNA anchor, normally not that sensitive to different bowsprit installations but needs to be positioned far forward in the bowsprit and is a bit problematic to combine with a bow ladder

Guide - use bow roller PB11.
Works well in most cases.



GUIDE

Without fixed bow roller

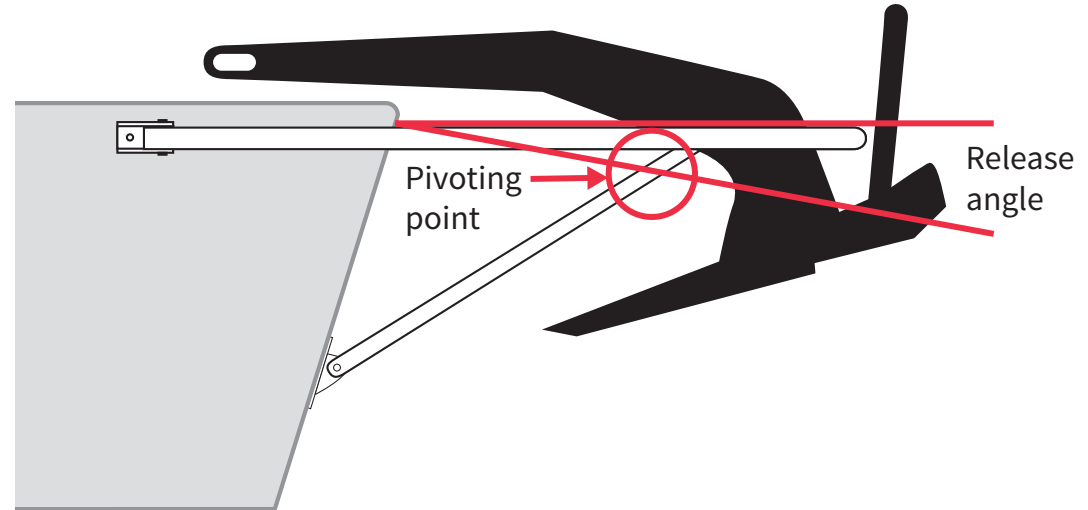

With fixed bow roller

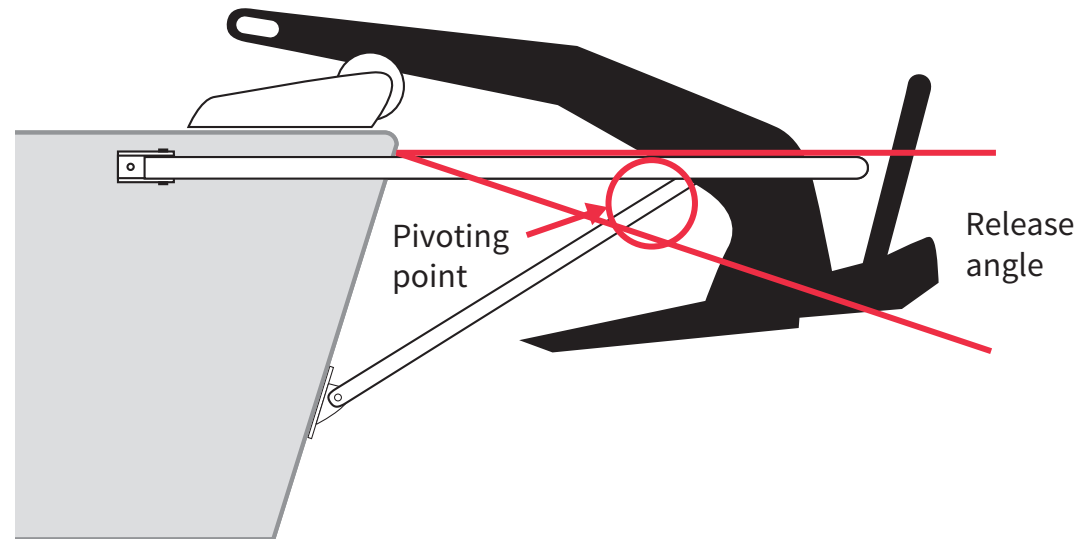

VULCAN type anchor in sailing position

It is important to find a good stowage position for the anchor in the bowsprit where it can be fixed and remain stable during sailing. Maybe your boat already has an existing fixed bow roller in the front? In that case you may keep it using it together with the roller on the bowsprit to jointly support your anchor. As seen, the anchor is then stored with a slightly larger release angle.

Example of a VULCAN anchor that is a bit sensitive to bigger S measurements where the anchor has a tendency to rotate forward around its pivoting point and with that it will hang down a bit.

Guide is to reduce the S measurement as much as possible by using a pivoting roller P1308 mounted upside/down and try to install the bowsprit as high as possible.



GUIDE

Without fixed bow roller

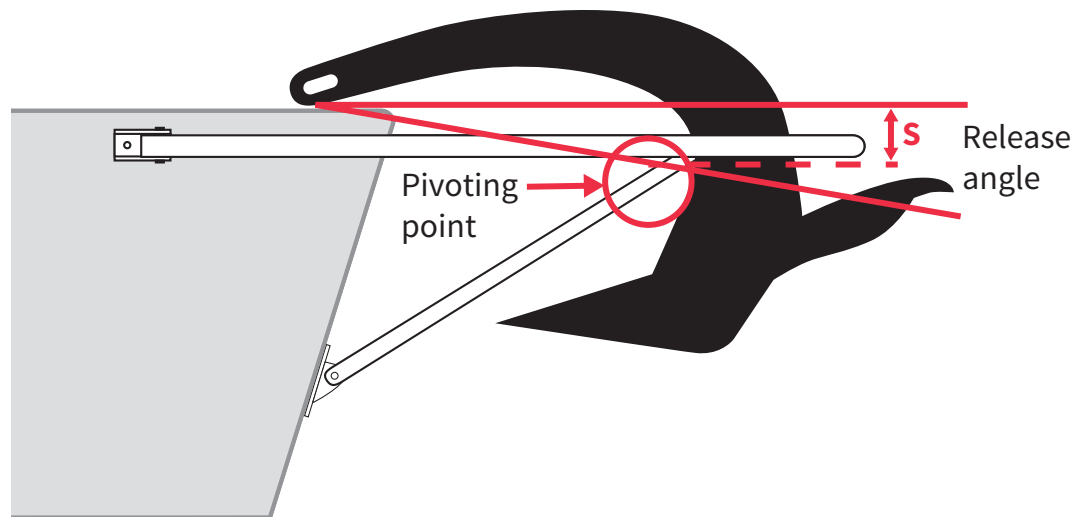

With fixed bow roller

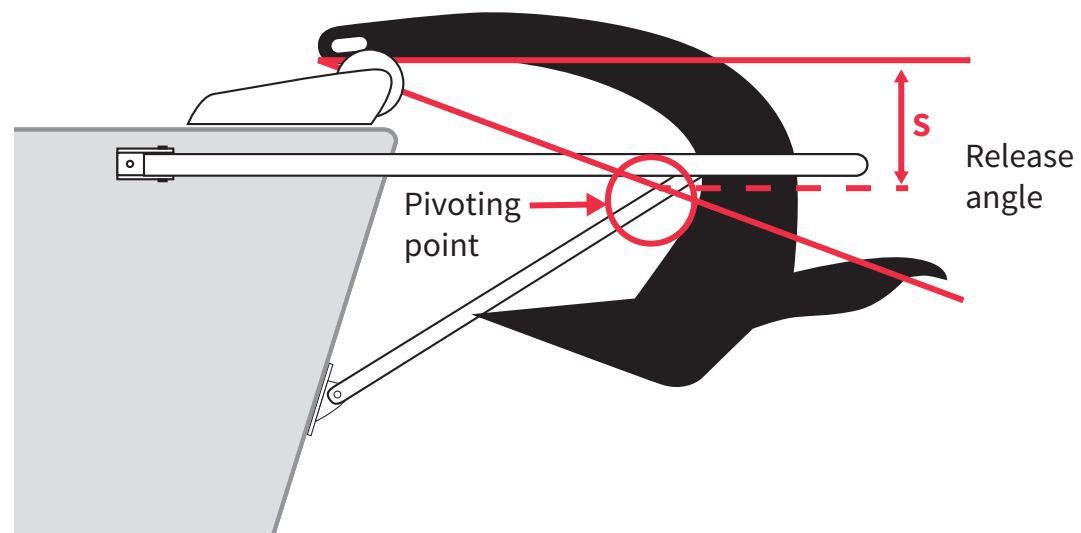

BRUCE type anchor in sailing position

It is important to find a good stowage position for the anchor in the bowsprit where it can be fixed and remain stable during sailing. Maybe your boat already has an existing fixed bow roller in the front? In that case you may keep it using it together with the roller on the bowsprit to jointly support your anchor. As seen, the anchor is then stored with a slightly larger release angle.

Example of a BRUCE anchor that normally is a very stable bowsprit anchor due to the straight shank. The sharp neck can have a tendency to get stuck in the fore part of the bowsprit anchor case.

To support an easier release, we propose to use a pivoting anchor roller model P1301 for anchors up to 15 kg. This will move pivoting point closer to the anchors center of gravity.



GUIDE

Without fixed bow roller

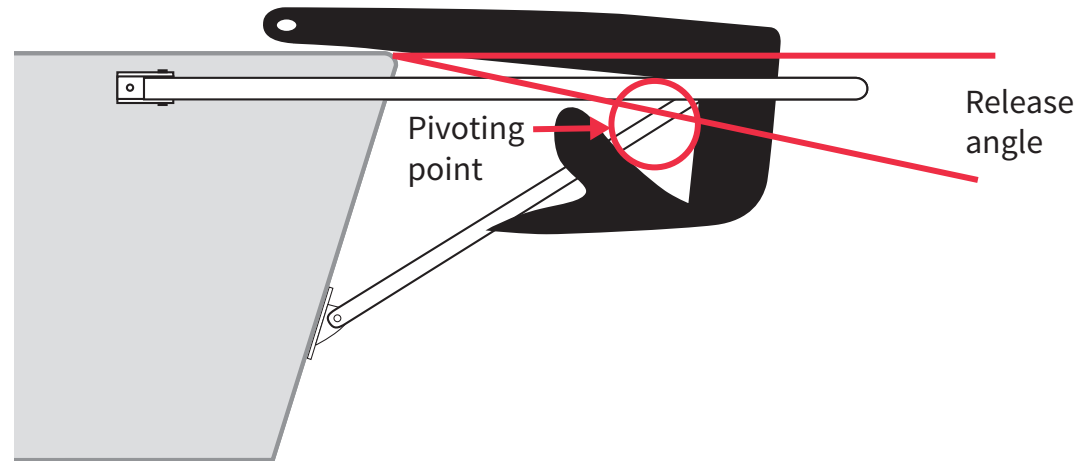

With fixed bow roller

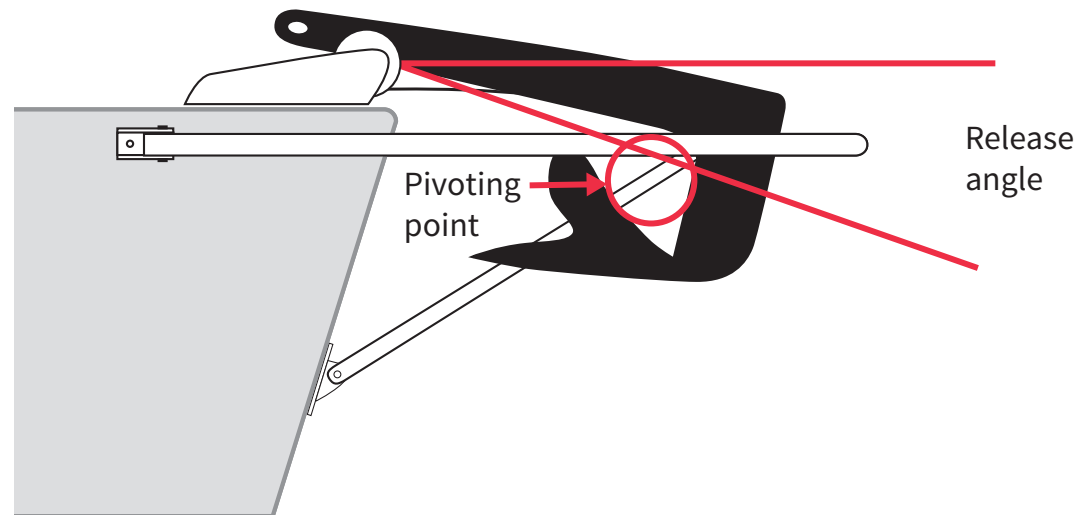

ULTIMATE



The Ultimate Series is a new bowsprit specially designed for extreme sea conditions, challenging anchoring and for serious cruisers accepting nothing but simply ultimate strength. The heavily reinforced waterstay in the Ultimate series is here to take massive loads, not only for ultimate Code-0 sailing, but for literally any violent forces created by the sea. No waves will bend the Ultimate bowsprit, no matter how much clashing green water when beating against a fierce swell! It withstands not only unprotected anchoring but takes you anywhere you want to sail. Made for boats up to 47 feet and 20 tonnes and anchors up to 33 kg.



ULTIMATE WATER STAY



Art	Description	L (mm)
500447	Ultimate Waterstay, long	1174-1464
500448	Ultimate Waterstay, short	684-974

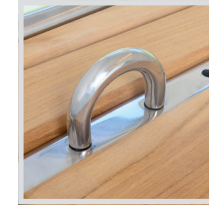

Code-0

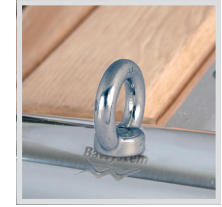

Gennaker fitting
Standard.

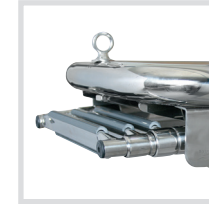

Ladder
Ladder in casing or hook
ladder as an option.

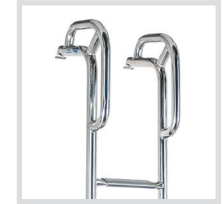

Hook-on ladder
For easy and quick
removal.



Evolution fittings
Standard for the
Ultimate series.



Water stay
Stay for extreme sailing.



Anchor holder/
anchor roller

Art	L (mm)	B (mm)	Tube (mm)	For boats	For gennaker	Step surface	Rec. anchor	Code-0 Load	Waterstay options	Fitting ladder	Fitting pulpit
ULT1200	1180	532 +/-50	42	32'-39'	115 m2	Teak	Max 20 kg	Max 2500 kg	500447 or 500448	BKT73A, BU76P-12	PPK600, PPK900
ULT1400	1400	590	42	39'-47'	130 m2	Teak	Max 25 kg	Max 2500 kg	500447 or 500448	BKT73A, BU76P-12	PPK800, PPK900
ULT1500	1500	630	50	39'-47'	150 m2	Teak	Max 33 kg	Max 2500 kg	500447 or 500448	BU76P-12	PPK800, PPK900



PERFORMANCE

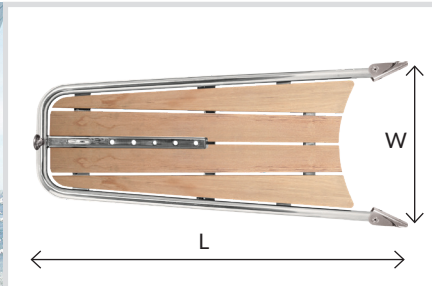

The Performance Series consists of bowsprits for sailing yachts. The special emphasis is put on design, functionality, and performance. The bowsprits are perfect for sailors wanting to get the most out of modern Code- or Gennakersailing. The adjustable upper anchor roller is suitable for most frequently used anchors on the market, up to 20 or 30 kg. The bowsprit also allows for a combination of a 20 kg anchor and a telescopic ladder in casing.

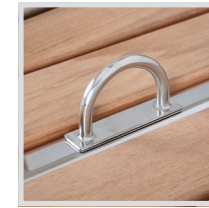

Code-0

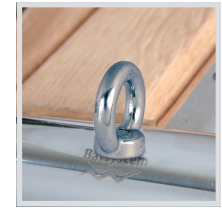

Gennaker fitting
Standard.

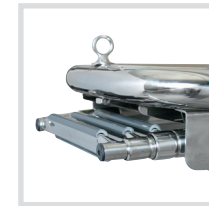

Ladder
Ladder in casing or hook
ladder as an option.



Hook-on ladder
For easy and quick
removal.



End fittings
With flush mounted bolts.



Evolution fittings
Optional fittings.

HANDLES



Art	Width (mm)	Height (mm)	Tube (mm)	Fitting dim (mm)
H250	250	65	25	32
H300	300	65	25	42



Art	L (mm)	W (mm)	Tube (mm)	For boats	For gennaker	Step surface	Rec Anchor.	Code-0 load	Fitting ladder	Fitting pulpit
PB1050	1050	435 +/-50	32	26'-33'	80 m ²	Teak	Max 16 kg	Max 1500 kg	BKT73, BKT73T, BU75P, BU75P-4	PPK600
PB1050BL	1050	435 +/-50	32	26'-33'	80 m ²	Blackline	Max 16 kg	Max 1500 kg	BKT73, BKT73T, BU75P, BU75P-4	PPK600
PB1200	1180	532 +/-50	42	32'-39'	115 m ²	Teak	Max 20 kg	Max 2500 kg	BKT73A, BU76P-12	PPK600, PPK900
PB1200BL	1180	532 +/-50	42	32'-39'	115 m ²	Blackline	Max 20 kg	Max 2500 kg	BKT73A, BU76P-12	PPK600, PPK900
PB1400	1400	590	42	39'-47'	130 m ²	Teak	Max 25 kg	Max 2500 kg	BKT73A, BU76P-12	PPK800, PPK900
PB1400BL	1400	590	42	39'-47'	130 m ²	Blackline	Max 25 kg	Max 2500 kg	BKT73A, BU76P-12	PPK800, PPK900



Blackline/Teak/
EVA
Choose between Black-
line, Teak or EVA.



Anchor holder/
anchor roller



EDGE

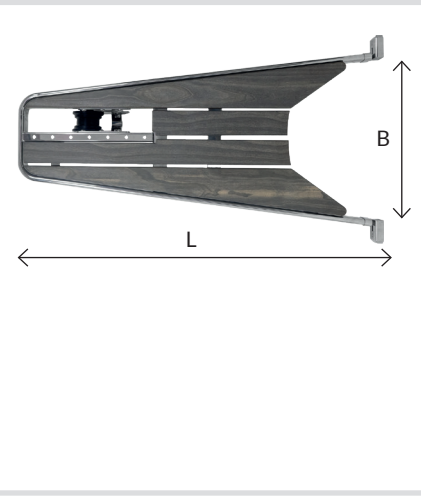

The modified frame design makes the bow platform become a natural integrated part of the boat with its slender shape and hull fittings.

Registered EU design



Code-0



EDGE fittings

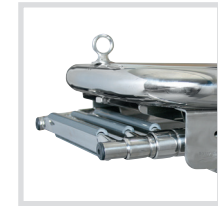

Ladder
Ladder in casing or hook ladder as an option.



Hook-on ladder
For easy and quick removal.



Anchor Cradle
Registered EU design



Art	L (mm)	B (mm)	Tube (mm)	For boats	For gennaker	Step surface	Rec. anchor	Code-0 Load	Waterstay options	Fitting ladder
ED1200	1180	532 +/-50	42	32'-39'	115 m2	Accoya	Max 20 kg	Max 2500 kg	500447 or 500448	BKT73A, BU76P-12

ACCOYA WOOD

With the new EDGE bowsprit series we introduce the use of a new boarding material made out of Accoya® Wood, and more specifically the colored through Accoya® Color decking light grey.



A sustainable choice

Accoya® Wood is non-toxic and 100% biodegradable. The material is a modified wood made out of Radiata Pine. The modification process called acetylation removes the wood's ability to bind water, with the consequence that it does not rot or swell. The manufacturer has a lot of certifications found at www.accoya.com



A durable material

Accoya® Wood has undergone very rigorous tests where the results in many cases show that it has better properties even in comparison to classic teak. The process that binds water also makes the material dimensionally stable in wet and dry conditions. The material is also UV-stable and shows no signs of degradation in saltwater environment.



RACE

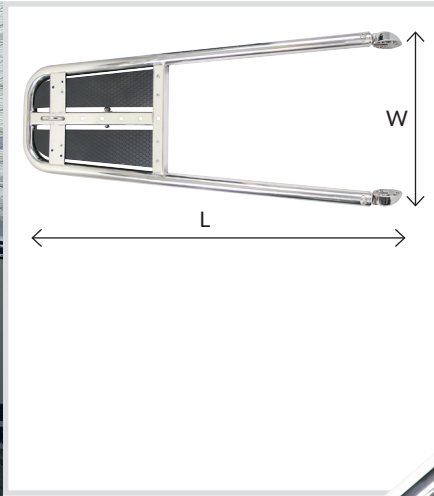

The Race bowsprits are developed with sailing performance in focus. Designed for Code-0 and gennaker sails and with a stripped-down racing design, it's the perfect option for sailors who aim for an amazing sailing experience, still enjoying full comfort and security while getting onboard or off the boat.



RACE80

RACE100

Art	L (mm)	W (mm)	Tube (mm)	For boats	For gennaker	Step surface	Code-0 Load	Fitting ladder
RACE80	800	330	32	26'-33'	80 m ²	Blackline	Max 1500 kg	BU75P, BU75P-4
RACE100	1000	390	42	32'-39'	130 m ²	Blackline	Max 2500 kg	BU75P, BU75P-4

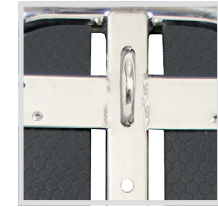

Code-0
Standard.



Evolution fitting
Standard.



Strut
Adjustable in length and position to cope with heavier loads.



Gennaker fitting
Standard.

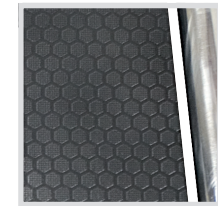

Blackline



Ladder
Hook ladder as an option.



When sailing with a Code-0 sail, huge triaxial forces attack both horizontally and vertically. A removable or retractable bowsprit is not designed to cope with these forces. Code-0 sails require a much more sturdy tripod construction, that still is light and facilitates a quick and efficient attachment of the sail.

CLASSIC



A series of bowsprits for classic boats with the main focus on simplifying getting on and off the boat. Can be combined with a ladder and an anchor up to 10 kg. Compatible with Gennaker between 50 and 80 m².

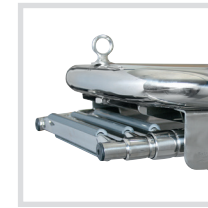

Ladder
Ladder in casing or hook ladder as an option.



Anchor holder
Pivoting anchor roller.



Anchor holder



HP65 GPT100 / GPAT100

Art	L (mm)	W (mm)	Tube (mm)	For boats	For gennaker	Step surface	Standard anchor roller	Rec Anchor	Fitting ladder	Fitting pulpit
HP65	650	330	32	18'-26'	50 m2	Teak	1402, accessory	10 kg	BKT72-250, BKT73-250, BU60P	-
GPT100	1160	530 +/-50	32	26'-33'	80 m2	Teak	-	-	BKT72, BKT73, BKT73T, BU75P, BU75P-4	PPK600, PPK900
GPAT100	1160	530 +/-50	32	26'-33'	80 m2	Teak	P1301	10 kg	BKT72, BKT73, BKT73T, BU75P, BU75P-4	PPK600, PPK900

COMFORT LADDERS

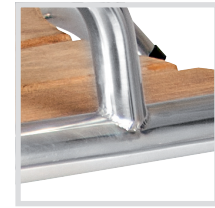
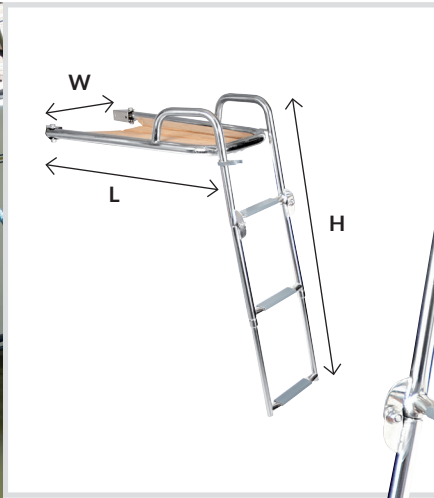

Welded ladder
For better stability.



Fixed handles
For better grip.



Foldable ladder
Telescopic.

Bowsprits with welded ladders and sturdy grips for better stability.



BUT26HP

BUT48PB

BUT26

BUT48

Art	L (mm)	W (mm)	H (mm)	Handle height	Steps	Products
BUT26HP	650	330	928	100	3	BUT26, HP65 welded
BUT48PB	1180	532	1120	350	3	BUT48, PB1200 welded
BUT26	218	293 cc	928	100	3	BUT26 for welding
BUT48	350	376 cc	1120	350	3	BUT48 for welding



PULPITS / STANCHIONS / HANDLES / CODE-0 KIT

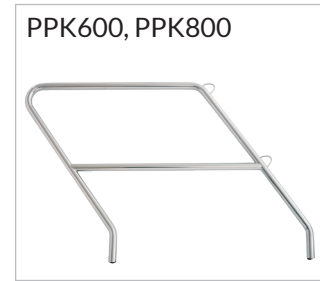

PULPIT

Art	Width (mm)	Height (mm)	Tube (mm)	Description
PP350	350	500	25	
PP350-1	350	500	25	Small pupit for deck mounting
PPK500	480	500	25	
PPK600	600	600	25	
PP620	315	620	25	Pulpit for mounting in stanchion socket
PPK800	800	610	25	
PPK900	800	625	25	

STANCHIONS

Art	Height (mm)	Description
2945S	610	Stanchion welded top
2941		Stanchion socket 90°
2942		Stanchion socket 84°

CODE-0 KIT

Art	Lenght (mm)
P10044	800
P10044-1	1000

HANDLE

Art	Width (mm)	Height (mm)	Tube (mm)	Fitting dim (mm)
H250	250	65	25	32
H300	300	65	25	42

EVOLUTION FITTING

Art	Tube (mm)
P1086	32
P1087	42

ANCHOR ROLLERS / ANCHOR HOLDERS



P1310 - Registered EU design.

ANCHOR ROLLER

Art	Width (mm)	Height (mm)	Max load	Anchor type
P1301	200	185	15 kg	BRUCE type
P1308	205	200	20 kg	DELTA/ROCNA type
P1307	235	235	30 kg	DELTA/ROCNA type
P1310			20 kg	Multi functional (for EDGE and PERFORMANCE)
P1306	75	Ø150	50 kg	
PB11	70	Ø110	50 kg	
1402	Anchor roller for HP65, MP550		10 kg	
P1309	Anchor lock. L=105 mm, B (max) 90 mm.			



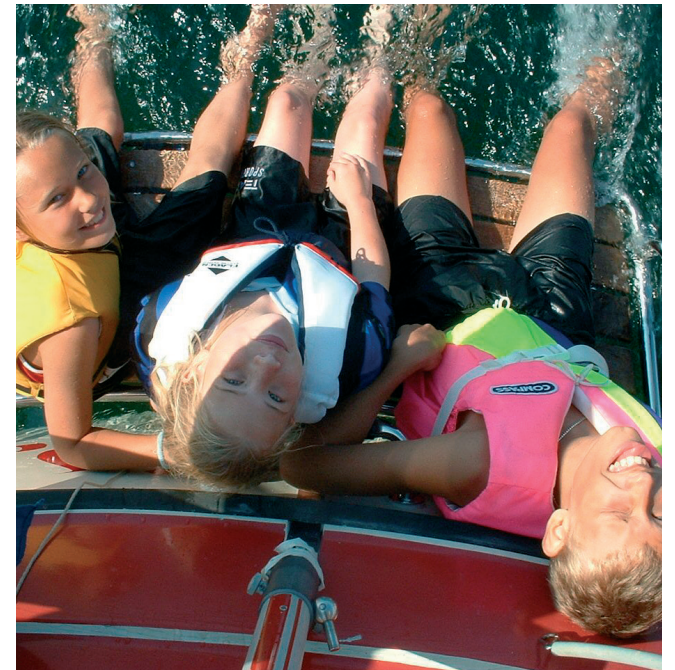

STERN PLATFORMS

Get closer to the water

Does the water seem too far away when you are at sea? Do you avoid water activities such as inshore swimming or fishing, because it seems too difficult to drag yourself up afterwards? A stern platform gets you closer to the water, and will get you safely back onboard again - even in a MOB situation! Besides making stern mooring and anchoring easier, it also helps you access your dinghy, or just hanging out watching the sunset.



GUIDE | STEP-BY-STEP

- 1 There is a model for every sailboat**
The range of products cover different sizes of models for stern platforms. With negative or positive transom. For a narrow or a wide transom. For external rudder.
- 2 Shape and size of your transom**
Measure the width of your transom approximately 300-400 mm above the waterline. If placed lower, it may drag in the water at higher speed on a close reach or when motoring. Make sure you have access and space on the inside of the transom to fit the washer and nut on the bolt. All models are slightly rounded towards the transom to align nicely to the shape of the boat.
- 3 Choose a model that suits you and your boat**
A stern platform is there for your convenience and safety. For swimming and bathing as well as a place for a MOB-ladder. For Scandinavian mooring it is also a good place for an anchor roller. See also illustrations on next coming pages.

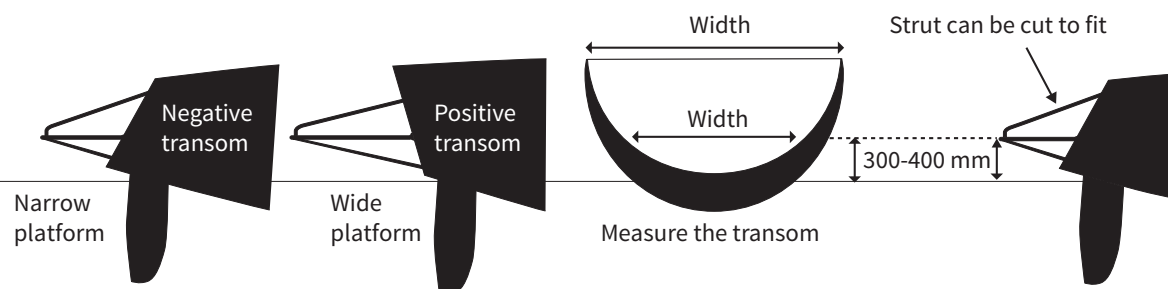

35 SERIES

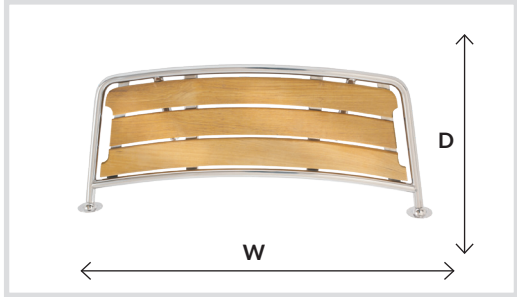

PT8035 PT10035 PT1253530 PT1553530



The platforms are equipped with a safety grip that is easy to grab and hold on to while bathing or in a "man overboard" situation.



Ladder in casing
As an option.



Safety grip
For better grip.



Adjustable struts
Horizontally and vertically.



Art	W (mm)	D (mm)	Tube (mm)	Step surface	Recommended ladders
PT8035	840	380	25	Teak	BKT73, BKT73T, BKT74, BKT74T
PT10035	1000	380	25	Teak	BKT73, BKT73T, BKT74, BKT74T
PT1253530	1270	410	32	Teak	BKT73, BKT73T, BKT74, BKT74T
PT1553530	1550	410	32	Teak	BKT73, BKT73T, BKT74, BKT74T

45 SERIES

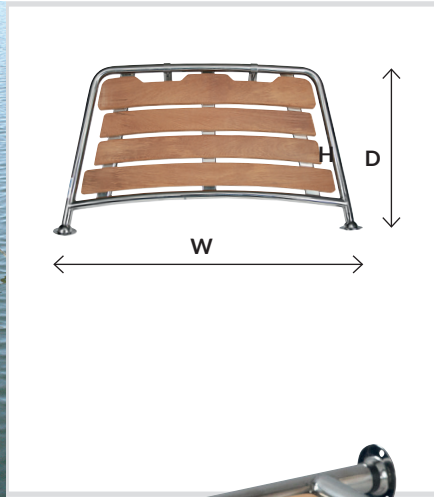

Functional stern platforms for sailing yachts. The 45 series is equipped with safety grips which are easy to grab and hold on to while swimming or in a MOB situation. The telescopic struts can be adjusted horizontally and vertically, making it easy to mount the platform on many different types of boats and sterns.



Ladder in casing
As an option.



Safety grip
For better grip.



Adjustable struts
Horizontally and vertically.



PT8045



PT1104530

Art	W (mm)	D(mm)	Tube(mm)	Step surface	Recommended ladders
PT8045	840	450	25	Teak	BKT73, BKT73T, BKT74, BKT74T
PT1104530	1040	450	32	Teak	BKT73, BKT73T, BKT74, BKT74T



45 Series - functional design with safety grips and adjustable telescopic struts.

60 SERIES

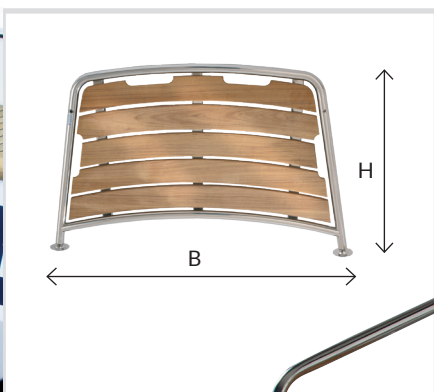

Functional stern platforms for larger yachts. Five parallel teak boards and supportive struts on the top. Two of the platforms are equipped with safety grips.



Ladder in casing
As an option.



Struts upwards
For better stability.

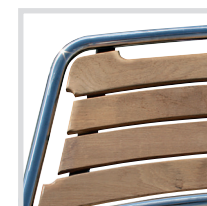

Safety grip
Available on PT1006030
and PT1256030



PT1006030



PT1256030



PR1306030

Art	B (mm)	H (mm)	Tube (mm)	Step surface	Recommended ladders
PT1006030	1090	600	32	Teak	BKT73, BKT73T, BKTH73, BKT74, BKT74T, BKTH74, BUT45, BUT47
PT1256030	1310	600	32	Teak	BKT73, BKT73T, BKTH73, BKT74, BKT74T, BKTH74, BUT45, BUT47
PR1306030	1300	600	32	Teak	BT70, BKT73-250



PR1306030 for sailboats with surface-mounted rudder.

DAVITS AND CRANES

Dinghy in good company

Do not let your dinghy weigh you down, or hang loosely in long dangling ropes. With a flexible and reliable davit you keep the dinghy off the boat, and still tightly attached during sailing. The smart construction minimizes the total length of your sailing yacht and doesn't make it tail-heavy. Complement with a bathing platform, and embarking/disembarking will be a piece of cake.

The design does not need any reinforcement of the transom so often necessary with fixed davits: Båtsystem davit only knows pulling and pushing forces, but no torque!

And best of all: the davits are quickly removed by simply pulling a singly bolt, easily reducing the overall length of your boat to your original deck length. Handy for racing and important when negotiating the price for your home berth!



GUIDE | STEP-BY-STEP

- 1 Maximum flexibility for installation!**
Båtsystem Davits come in three sizes and can hold 50kg, 100kg or 150kg per arm. In extreme situations, however, consider that the full weight of your dinghy including fuel, equipment and outboard engine might hang on one arm only, so your total weight should be able to be held by one arm only.

The models also differ in length, so check how far aft of your transom you wish to pick up your dinghy and how high up you wish it to hang. The davit fittings can be placed vertically on your transom or even horizontally on your deck.

- 2 Align the davit arm position with the dinghy's lifting eyes**
To optimize lifting efficiency and minimize stress on your boat, position the davits on your transom so that the lifting path is as vertical as possible.

- 3 In harmony with your boat**
For a harmonious and balanced look, it's essential to select davits that are proportionate to your boat and dinghy. Oversized or undersized davits can detract from your vessel's overall appeal.

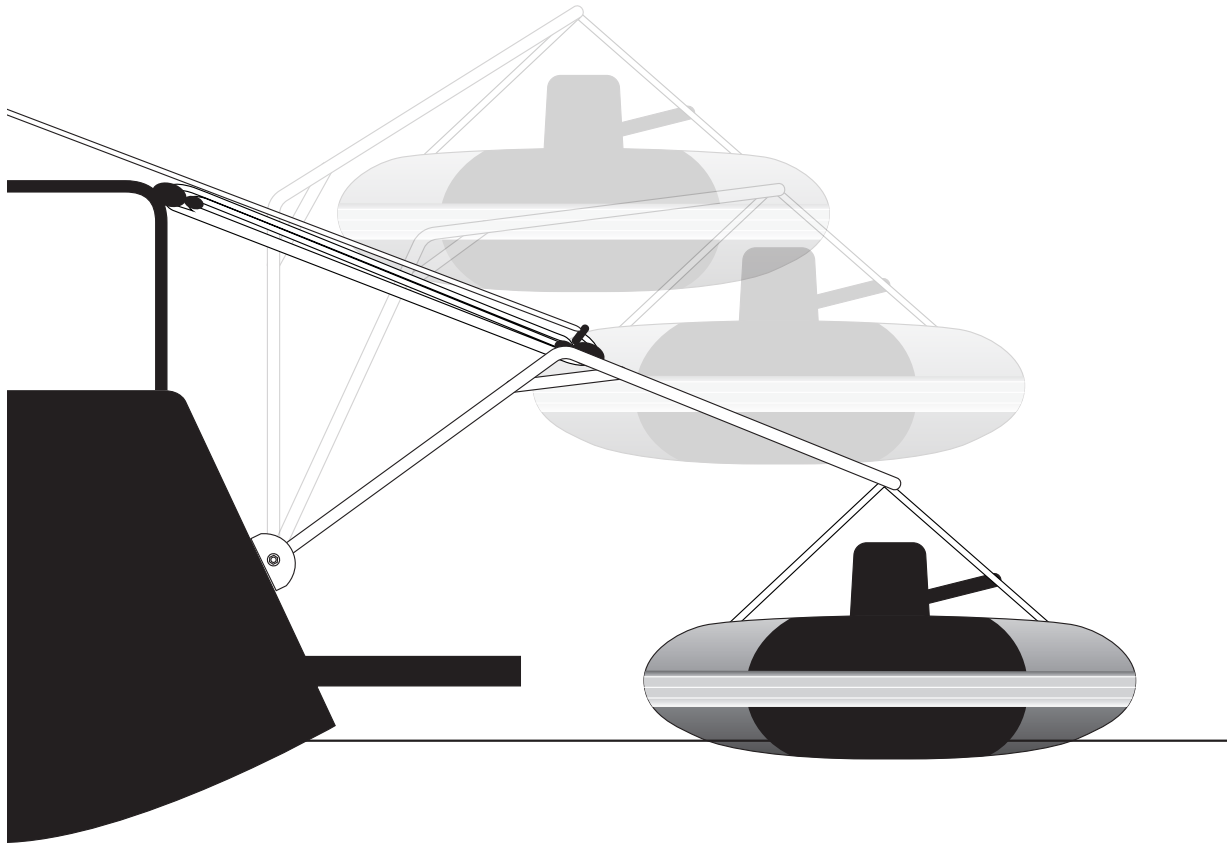

Båtsystem davits are engineered to eliminate torque on your transom

The unique design ensures a pure push against the transom and a pull through the block and line, reducing the risk of cracks or damage, especially when lifting or sailing with a heavy, waterlogged dinghy. The design does not need any reinforcement of the transom so often necessary with fixed davits.



DAVITS

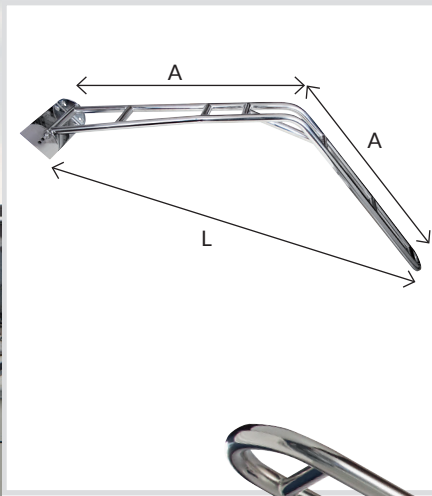

Sturdy, flexible and reliable davit. Easy to mount and dismount and can be retrofitted with no need for reinforcements of your boat's transom. The davits are available with two different stern fittings, one for a straight stern and one for an angled or rounded stern. The smart design uses only pulling and pushing forces, allowing the davit to move both vertically and horizontally, which optimizes the centre of gravity and keeps the dinghy off the boat.

Manufactured in stainless AiSI 316 steel, polished to a high gloss finish. Sets of blocks and ropes are included in the davit kits

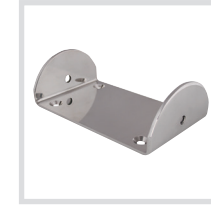

Straight fitting
For straight stern.



Angled fitting
5, 10 or 15 degrees. For rounded stern. For most sailing boats.



Disassembly
Through bolt for easy removal.



Set of blocks
Included in the kits.



DV25 DV32 DV42



Art	L (mm)	A (mm)	Fitting (mm)	Max load/davit (kg)	Kit
DV25	1300	750	200x120	50	
DV25-1	1300	750	200x120, angled (5°, 10°, 15°)	50	
DV25 KIT	1300	750	200x120	50	2 x DV25, DV-block
DV25-1 KIT	1300	750	200x120, angled (5°, 10°, 15°)	50	2 x DV25-1, DV-block
DV32	1530	875	260x160	100	
DV32-1	1530	875	260x160, angled (5°, 10°, 15°)	100	
DV32 KIT	1530	875	260x160	100	2 x DV32, DV-block
DV32-1 KIT	1530	875	260x160, angled (5°, 10°, 15°)	100	2 x DV32-1, DV-block
DV42	1740	993	307x160	150	
DV42-1	1740	993	307x160, angled (5°, 10°, 15°)	150	
DV42 KIT	1740	993	307x160	150	2 x DV42, DV-block
DV42-1 KIT	1740	993	307x160, angled (5°, 10°, 15°)	150	2 x DV42-1, DV-block



ACCESSORIES

P1112, P1121,
P1122



P1110, P1125,
P1126



DV-block



DV-42block



Art	Description
P1112	Straight fitting 90°. For DV25
P1110	Angled fitting 5°, 10°, 15°. For DV25
P1121	Straight fitting 90°. For DV32
P1125	Angled fitting 5°, 10°, 15°. For DV32
P1122	Straight fitting 90°. For DV42
P1126	Angled fitting 5°, 10°, 15°. For DV42
DV-block	Accessories for 1 davit arm. Cordage, Seldén mainsheet block (4-cut)
DV-42block	Accessories for 1 davit arm. Cordage, Seldén mainsheet block (6-cut)



More mounting options in our gallery
at www.boatsystemgroup.com

CRANE



A smart crane for mounting on deck and in the pushpit. Easy to mount on and take off. The crane can lift 50 kg and is suitable to hoist up the outboard or for loading.



Pulpit not included



Block fitting
Fitting for block winch.



Pulpit fitting
For stability.



Rod coupling
Easy to mount on and off the crane.



Art	Description	L (mm)	L1 (mm)	L2 (mm)	B (mm)	Max load	Tube
Crane 42	Crane with blocks	1750	950	800	550	50 kg	Ø42mm



ANCHORING

Smoother bow-to mooring

Imagine sliding into the harbour, easily manoeuvring your boat while you have full control over your stern-anchor. An anchor in a ready-to-go position make your boat life so much easier when mooring bow-to.

A windlass system makes it easy to launch the stern-anchor, even under the hardest circumstances. When leaving the harbour, you just push the button, let the windlass drag your boat out to the anchor and hoist it up easily.

Another application for a stern anchor is to point your bow into the swell when anchoring with your bow anchor. You may forget roly nights at anchor by simply using your stern anchor as a kedge.



GUIDE | STEP-BY-STEP

- 1 Simplify your sailing life with a secure stern anchor stowage solution**
Our range of models fits various transoms and windlasses.
- 2 Looking for the ideal solution for your boat's anchor setup?**
Leverage our expertise and extensive library of customer projects. We'll find the perfect installation for your specific boat.
- 3 Properly stowing your anchor on your sailboat is crucial for safety and optimal performance**
Secure loose items and protect your equipment from the elements. Be ready for your next adventure.

ANCHOR HOLDERS & ANCHOR DAVITS

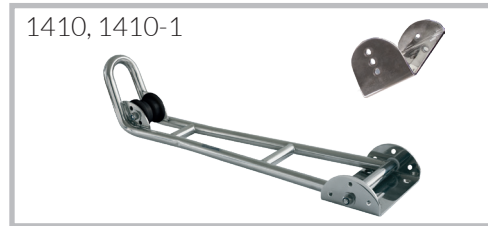
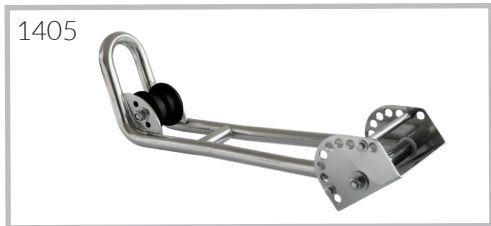
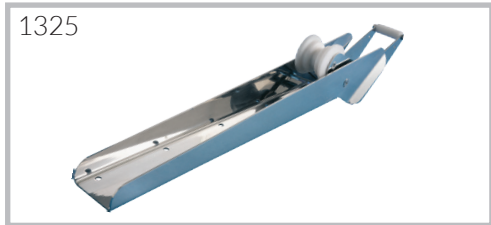
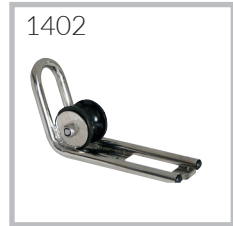
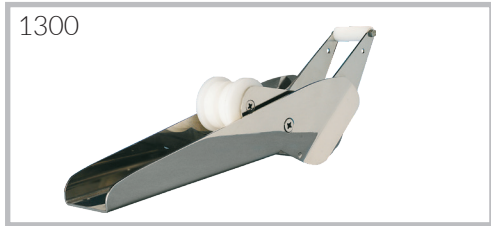

Art.	Length (mm)	Width (mm)	Fitting (mm)	Max load (kg)	Function
1300	450	80	280x80	15	
1325	680	80	530x80	15	
1326	400	145	80x335	15	Folded
1402	200	80	99x80 c/c	10	Fits HP65, MP550
1400K	410	80	170x80 c/c	15	
1400	510	80	125x80 c/c	15	
1405	525	-	120x150, tiltable	15	
1410	726	-	120x200, tiltable	20	
1410-1	726	-	120x200, tiltable	20	Tilted fitting
1420	726	-	120x200, tiltable	20	Strut, anchor locking
1420-1	726	-	120x200, tiltable	20	Strut, anchor locking, tilted fitting
P1116	-	-	-	-	Anchor tilt (1400, 1400K, 1405, 1410, 1410-1, 1420, 1420-1)
P1110	-	-	120 x 200	-	Tilted fitting (5°, 10°, 15°)
P1303	130	85	-	-	Anchor roller

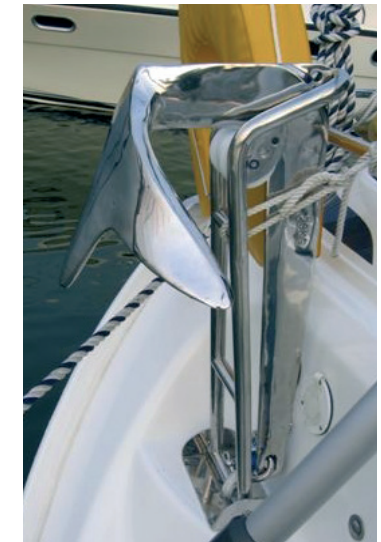

DECK EQUIPMENT

Enhance your sailing experience with our selection of boarding accessories

From sturdy grab rails to non-slip steps, we have everything you need to board your sailboat safely and easily.



BOLLARDS

Art	Height (mm)	Diameter (mm)	Foot (mm)	Bolt	Description
BP50095	95	Ø50	91x91	M6	
BP70145	145	Ø70	120x140	M8	
BP80200	200	Ø76	125x200	M12	
BPL80200	200	Ø76	125x200	M12	6 LED, 12V, 6x0,15W



FOOTSTEPS

F2890, F2820, F2840, 160W



Art	Description
F2890	Footstep 90°, c/c 28 cm
F2820	Footstep 20°, c/c 28 cm
F2840	Footstep 40°, c/c 28 cm
160W	Teakstep (for footstep)

CLEATS

Art	H (mm)	B (mm)	Foot (mm)	Bolt	C/C mm	Description
P145	43	145	90x31	M8	50	Cleat
P200	54	200	120x35	M10	69	Cleat
P285	80	285	160x40	M12	100	Cleat
PB285	-	-	160x40	M12	100	Plate

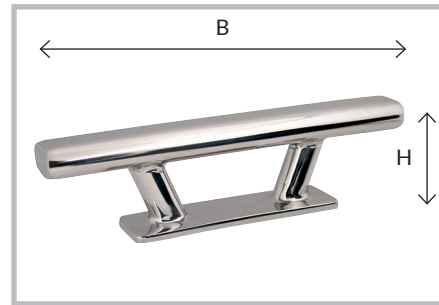

HANDLES

H250



Art	Width (mm)	Height (mm)	Tube (mm)	Fitting dim (mm)
H250	250	65	25	32
H300	300	65	25	42

MODULAR GRAB RAILS

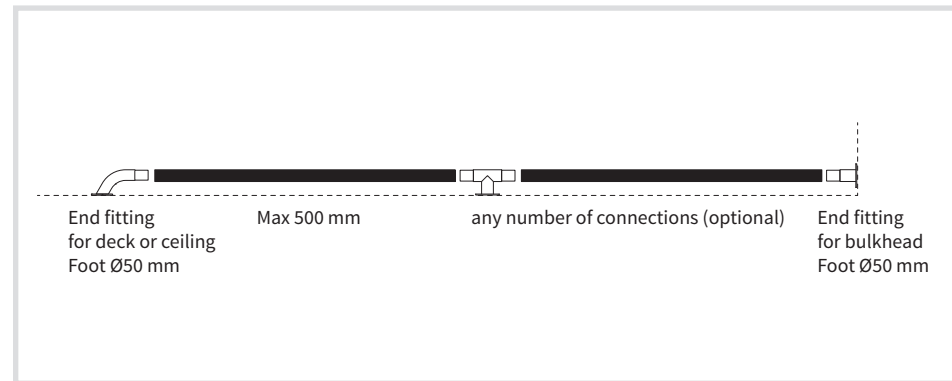

Art	H (mm)	L (mm)	Foot (mm)	Tube (mm)	Material
GRB-CF	60	-	Ø50	Ø25	Stainless steel
GRB-CF-T	60	-	Ø50	Ø25	Stainless steel
GRB-CF-E	-	-	Ø50	Ø25	Stainless steel
CF-TUBE-125	-	125	-	Ø25	Carbon fibre
CF-TUBE-250	-	250	-	Ø25	Carbon fibre
CF-TUBE-500	-	500	-	Ø25	Carbon fibre

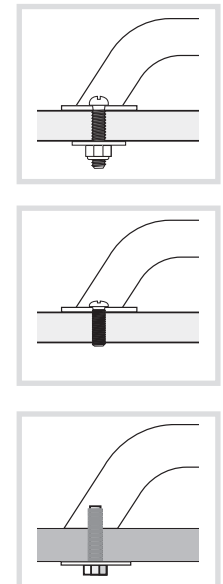

FITTINGS AND SPARE PARTS

<p>P1086</p>  <p>Bowsprit fitting, Ø32 mm</p>	<p>P1087</p>  <p>Bowsprit fitting, Ø42 mm</p>	<p>P1001</p>  <p>Bowsprit fitting, Ø42 mm</p>	<p>P1000</p>  <p>Bowsprit fitting, Ø32 mm</p>	<p>P1108</p>  <p>Bowsprit fitting for HP65</p>	<p>P1028</p>  <p>U-fitting, Ø32 mm</p>	<p>P1069</p>  <p>T-fitting, Ø55 mm</p>	<p>P1092</p>  <p>Gasket, universal fitting</p>	<p>P1066</p>  <p>Stainless tubeclip Ø25 mm with eyebolt</p>	<p>P1076</p>  <p>Stainless tubeclip, Ø25 mm</p>
<p>P1002</p>  <p>U-fitting, Ø25 mm</p>	<p>P1065</p>  <p>U-fitting, Ø25 mm, M8</p>	<p>P1004</p>  <p>U-fitting, Ø25 mm, M6</p>	<p>P1003</p>  <p>U-fitting, Ø22 mm</p>	<p>P1014</p>  <p>Universal fitting, Ø70 mm</p>	<p>P1068</p>  <p>Universal fitting, Ø62 mm</p>	<p>P1013</p>  <p>Keyhole fitting, Ø70 mm</p>	<p>P1041</p>  <p>Eyebolt, M8x50 mm</p>	<p>P1109</p>  <p>Eyebolt, M8x35 mm</p>	<p>P1036</p>  <p>Knob for stem ladder</p>
<p>P1071</p>  <p>Keyhole fitting, Ø62 mm</p>	<p>P1072</p>  <p>Keyhole fitting, Ø50 mm</p>	<p>P1059</p>  <p>Hook fitting for BU76P-12</p>	<p>P1008</p>  <p>Hook fitting for ladder</p>	<p>P1124</p>  <p>Hook fitting for ladder</p>	<p>P1009</p>  <p>Hook fitting for ladder</p>	<p>P1063</p>  <p>Washer: Ø 17,5 mm, Ø6 mm</p>	<p>P1045</p>  <p>Strut, bow ladder</p>	<p>P1025</p>  <p>Strut, bow ladder</p>	<p>P1101</p>  <p>Support for 1420 strut</p>
<p>P1011</p>  <p>Washer, Ø55 mm</p>	<p>P1012</p>  <p>Washer, 5°, Ø54 mm</p>	<p>P1119</p>  <p>Washer, 5° for P1014</p>	<p>P1048</p>  <p>Plastic washer, Ø25 mm</p>	<p>P1049</p>  <p>Plastic washer, Ø35 mm</p>	<p>P1016</p>  <p>End fitting, Ø25 mm, plastic</p>	<p>P1031</p>  <p>End fitting, Ø18,8 mm, plastic</p>	<p>P1070</p>  <p>Roll for P1301</p>	<p>P1306</p>  <p>Roll, Ø150 mm</p>	<p>P1103</p>  <p>Locking hook for 1420</p>
<p>P1019</p>  <p>End fitting, Ø42 mm, plastic</p>	<p>P1018</p>  <p>End fitting, Ø32 mm, plastic</p>	<p>P1058</p>  <p>End fitting, 25 mm, plastic</p>	<p>P1017</p>  <p>Adjustment plug for ST-ladders</p>	<p>P1033</p>  <p>Swivel, Ø25-Ø32 mm</p>	<p>P1027</p>  <p>Swivel, Ø25-Ø25 mm</p>	<p>P1030</p>  <p>Swivel, Ø32-Ø32 mm</p>	<p>P1074</p>  <p>Universal stay for MP750. Holes Ø10 mm. 150x25 mm</p>	<p>P1302</p>  <p>Bolt for anchor roller</p>	
<p>P1097</p>  <p>Tube clip, Ø25 mm</p>	<p>P1098</p>  <p>Tube clip, Ø32 mm</p>	<p>P1100</p>  <p>Tube clip, Ø38 mm</p>	<p>P1046</p>  <p>Tube clip, Ø38 mm</p>	<p>P1039</p>  <p>Tube clip, Ø32 mm</p>	<p>P1038</p>  <p>Tube clip, Ø25 mm</p>	<p>P1073</p>  <p>Tube clip, Ø22 mm</p>	<p>P1091</p>  <p>Universal stay for MP1000. Holes Ø10 mm. 290x30 mm</p>	<p>P1022</p>  <p>Strut for platform, 750 mm</p>	
<p>P1029</p>  <p>Bracket, Ø25 mm</p>	<p>P1006</p>  <p>Tube clip, Ø32 mm</p>	<p>P1005</p>  <p>Tube clip, Ø25 mm</p>	<p>P1010</p>  <p>Extension 50 mm, Ø32mm</p>	<p>P1085</p>  <p>Extension 30°, Ø32 mm</p>	<p>P1106</p>  <p>Extension 45°, Ø32 mm</p>	<p>P1104</p>  <p>Upper roll for P1301</p>	<p>P1107</p>  <p>Axis for 1300, 1325</p>	<p>P1115</p>  <p>Axis for P1301</p>	

More fittings and spare parts can be found on our website.







Båtsystem is a part of BSG
www.boatsystemgroup.com